



SJDH1200A电动扫路机使用说明书
Electric Road Sweeper



徐州徐工环境技术有限公司

XCMG XUZHOU ENVIRONMENT TECHNOLOGY CO., LTD.



产品技术规格

Technical specifications

a) SJDH1200A电动扫路机外形尺寸见图2-1

Refer to **Figure 2-1** for the dimension of the electric road sweeper.



图2-1 SJDH1200A电动扫路机外形廓尺寸图

Figure 2-1 Dimension of the electric road sweeper

b) 整机性能与结构参数见表2-1

Refer to **Figure 2-1** for the performance and structural specifications of the machine.

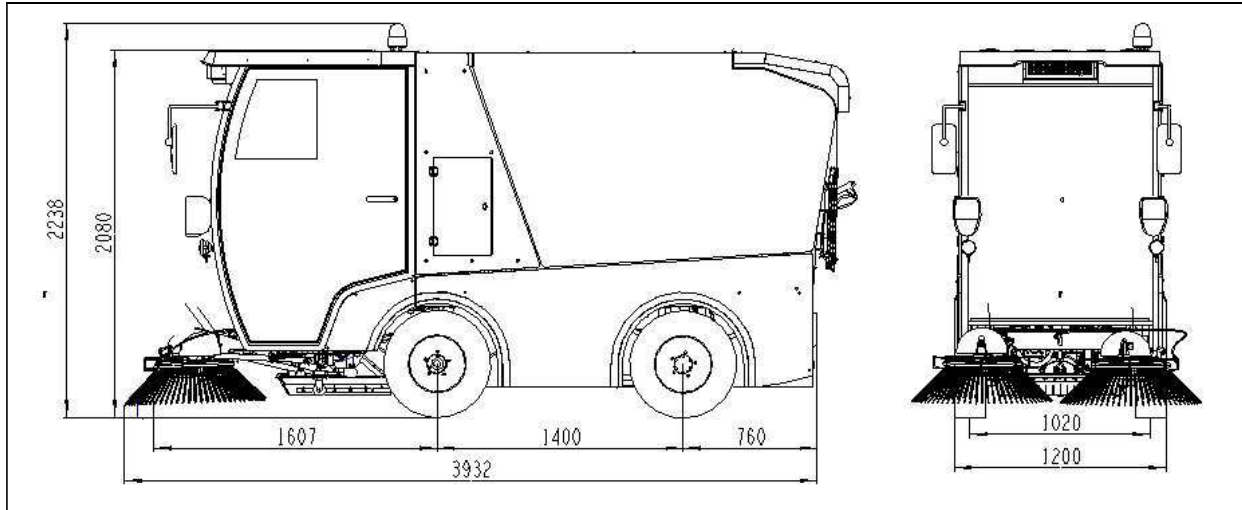
表2-1 整机性能与结构参数表

Table 2-1 Performance and structural specifications of the machine

项目 Description		单位 Unit	SJDH1200A
行驶性能 Driving performance	最高车速（满载） Max. speed (full-load)	km/h	25
	最大爬坡度 Max. gradeability	%	25
	制动距离 Brake distance	m	≤6.5
	最小转弯半径 Min. turning radius	m	≤3.5
质量参数 Weight	整机整备质量 Total weight	kg	≤2150
	最大允许总质量 Max. allowable weight	kg	3000



结构尺寸 Dimension	外廓尺寸（长×宽×高） Dimension (L x W x H)	mm	3950×1200×2080
	轴距 Wheelbase	mm	1400±2
	轮距 Tread	mm	1020
电池参数 Battery	电池类型 Battery type	—	磷酸铁锂 LFP
	电池总电量 Overall capacity	kW·h	30.3/40.7（选配） (Optional)
	电池额定电压 Rated voltage	V	72
	充电时间 Charging time	h	8~10
作业性能 Operating performance	垃圾箱容积 Garbage box capacity	L	1200
	清水箱容积 Clean water tank capacity	L	550
	垃圾箱卸料角 Discharging angle of the garbage box	°	45
	垃圾箱倾倒高度 Dumping height of the garbage box	mm	1400
	清扫作业能力 Cleaning capacity	m ² /h	24000
	清扫宽度 Cleaning width	mm	2000
	工作速度 Operating speed	km/h	1~12
	连续作业时间 Continuous operating time	h	6~8
	手持吸管长度 Length of the handheld suction pipe	mm	4000（选装） (Optional)

c) 加油（脂）加水一览表见表2-2

Refer to **Figure 2-2** for the instructions for oil (grease) and water filling

表2-2 加油（脂）加水一览表

Table 2-2 Instructions for oil (grease) and water filling



序号 No.	加注部位 Filling position	加注种类、牌号 Type and grade	加注量 Filling quantity
1	液压油箱 Hydraulic oil tank	L-HM46抗磨液压油 L-HM46 anti-abrasion hydraulic oil	6L
2	驱动桥 Drive axle	齿轮油 Gear oil	0.8L
3	所有油嘴 Oil nozzles	锂基润滑脂 Lithium lubricating grease	适量 Proper amount
4	清水箱 Clean water tank	清洁自来水 Clean tap water	550L
5	制动液罐 Brake fluid tank	制动液 Brake fluid	0.5L

